

Type1 Butterfly Laser Diode Mount

Features

The BTY-T1-XHS laser diode mount is designed for use with a 14-pin butterfly package Type1 Laser Diode. It features a small footprint high quality heat-sink that does not require forced convection for most Laser diodes. The mount has a single 10-pin XHS male connector to allow quick and simple connectivity.

Specifications

Polarity of LD	AG/CG
Polarity of PD	Floating
Max Laser Current	3A
Maximum TEC current	3A
Dimensions (WxLxH) mm	50X66X43

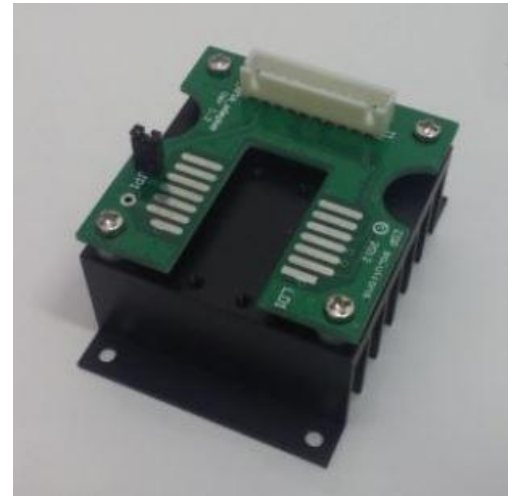

10-pin XH male connector Pinout J1

1	LD Cathode (-)
2	LD Anode (+)
3	Case Ground
4	PD Anode (+)
5	PD Cathode(-)
6	Thermistor
7	Thermistor
8	Case
9	TEC (-)
10	TEC (+)

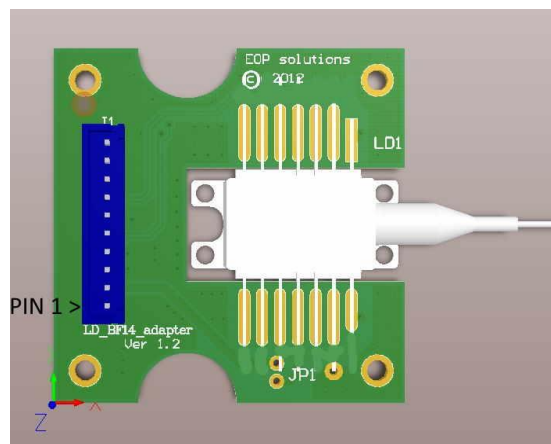

BFY-14 Type1 Laser Diode Pin Assignment

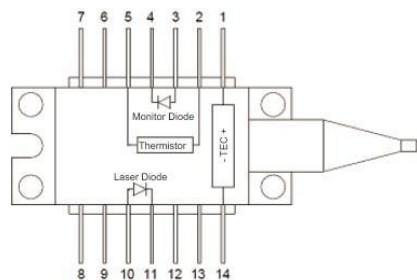

1	TEC (+)
2	Thermistor
3	PD Anode (+)
4	PD Cathode(-)
5	Thermistor
6	NC
7	NC
8	NC
9	NC
10	LD Anode (+)
11	LD Cathode (-)
12	NC
13	Case Ground
14	TEC (-)

Installation

Laser diodes produce heat. In order to maintain constant temperature a TEC is integrated into the 14-pin butterfly package. To utilize the TEC make sure to have good thermal contact between the 14-pin butterfly package and the mount heat sink. The use of thermal interface material between the package and the heat sink is strongly recommended. A good quality thermal grease or thermal interface pad can be used for this purpose.

After applying a small amount of thermal grease on the heat sink, the package should be mounted on the heat sink. The Laser diode may be damaged by ESD, make sure to take precaution and work in an ESD safe environment. The package should be secured to the heat sink using 4 screws. The screws should be tightened evenly in two stages. The package can be permanently distorted and damaged if the screws are tightened unevenly or over tightened.

JP1 jumper is installed by default and is protecting the Laser Diode from ESD damage by shortening it. Install JP1 jumper when Laser Diode is disconnected from the current source to protect from ESD damage.

Make sure to remove jumper JP1 after connecting the mount to the laser current source.

Heat sink dimensions and mounting holes

The Mount has 4 holes of 3.4mm on its base to secure it to a working surface. The length between the holes is 42mm on the 50mm side and 58mm on the 66mm side.

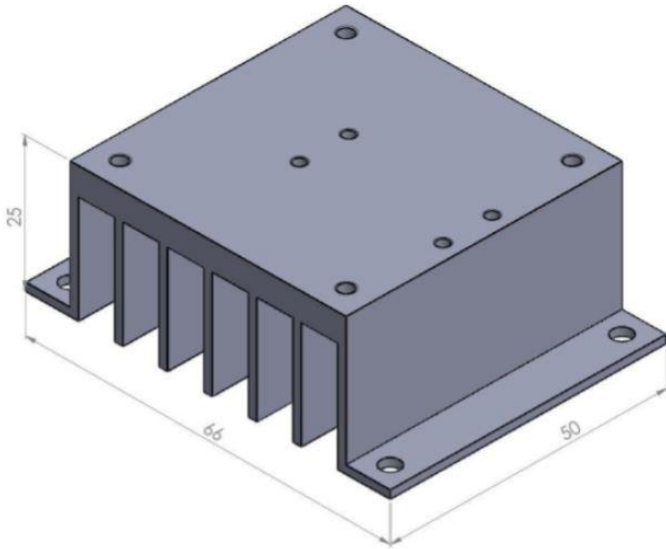

Warranty: 1Y Limited to Mount value.

For any enquiry sales@eloptech.com